



HAL
open science

Design criterion and finite element analysis of pure cubic system

Wu Zhenhang, Sébastien Seguy, Manuel Paredes, Donghai Qiu

► **To cite this version:**

Wu Zhenhang, Sébastien Seguy, Manuel Paredes, Donghai Qiu. Design criterion and finite element analysis of pure cubic system. Seventh Conference on Nonlinear Vibrations, Localization and Energy Transfer, Jul 2019, Marseille, France. hal-02179281

HAL Id: hal-02179281

<https://hal.insa-toulouse.fr/hal-02179281>

Submitted on 1 Jul 2021

HAL is a multi-disciplinary open access archive for the deposit and dissemination of scientific research documents, whether they are published or not. The documents may come from teaching and research institutions in France or abroad, or from public or private research centers.

L'archive ouverte pluridisciplinaire **HAL**, est destinée au dépôt et à la diffusion de documents scientifiques de niveau recherche, publiés ou non, émanant des établissements d'enseignement et de recherche français ou étrangers, des laboratoires publics ou privés.

Design criterion and finite element analysis of pure cubic system

**A. Zhenhang WU¹, B. Sébastien SEGUY¹, C. Manuel PAREDES¹
and D. Donghai QIU²**

¹ Institut Clément Ader (ICA), CNRS-INSA-ISAE-Mines Albi-UPS
Université de Toulouse, France
zhenhang.wu@insa-toulouse.fr
sebastien.seguy@insa-toulouse.fr
manuel.paredes@insa-toulouse.fr

² Suzhou Institute of Biomedical Engineering and Technology
Chinese Academy of Sciences, Suzhou, China
qiudh@sibet.ac.cn

Abstract The purpose of this abstract is to report a novel design of pure cubic stiffness system and general methodology to parameterize variable pitch spring. The performance of the improved design will be tested by finite element analysis (FEA).

In the studies of machining accuracies, devices that work under complex load conditions, and comfort, to name a few, vibration mitigation, is an inevitable issue. The traditional vibration absorber can be divided into three types: passive, active, and semi-active. Among these, the passive absorber Nonlinear Energy Sink (NES) attracts researcher's attention because of its lighter attachment and performance in a broader band of frequency.

This type absorber is characterized by a damped linear oscillator coupled to an essentially nonlinear attachment. When the NES meets certain conditions, such as proper mass ratio, nonlinear stiffness, and external excitation, it can be activated [1]. There exists regimes of the quasi-periodic response and leads to a passive irreversible transfer of primary structural energy (referred as energy pumping) towards secondary highly coupled mass via a nonlinear element [2].

The mastery of nonlinearity is a key issue to obtain the optimal vibration absorption performance. To obtain an optimally strong nonlinearity, a generalized methodology for designing a novel Nonlinear Energy Sink was established [3].

Firstly, a designed parameterization of variable pitch spring is implemented. Accordingly, the objective nonlinear Force-displacement function was divided into sections, whose stiffness were considered to be constant. The core of generating a variable pitch spring is adjusting its variable active coils during the compression. A symmetrical design method is applied to overcome the inaccuracy in the end of curve fitting.

Secondly, it is very challenging to produce a purely cubic stiffness by using variable pitch spring directly i.e., without a linear part (Figure 1). In order to overcome this shortcoming, two important steps were implemented: 1) a method of axial combination of two variable pitch springs and pre-compression at transition point was proposed. This produced the force polynomial component with only linear terms and cubic terms. 2) With the help of a negative stiffness mechanism that was designed with an axial coincidence having two cylindrical springs whose direction of movement is perpendicular to their axis. This mechanism can counterbalance the linear term and obtain the pure cubical stiffness.

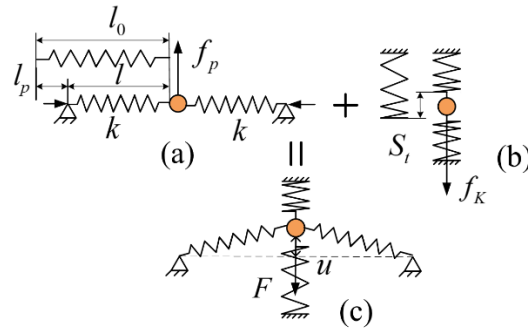

Figure 1: Detailed realization of NES system.

A finite element model of variable pitch spring was built by optimizing the geometry, adjusting and refining the mesh type, resetting the boundary conditions to carry out simulations (Figure 2). These parameters of simulations were adjusted to closely match the theoretical results. The current simulation results show that Abaqus can effectively simulate the compression characteristics of variable pitch springs (Figure 3)

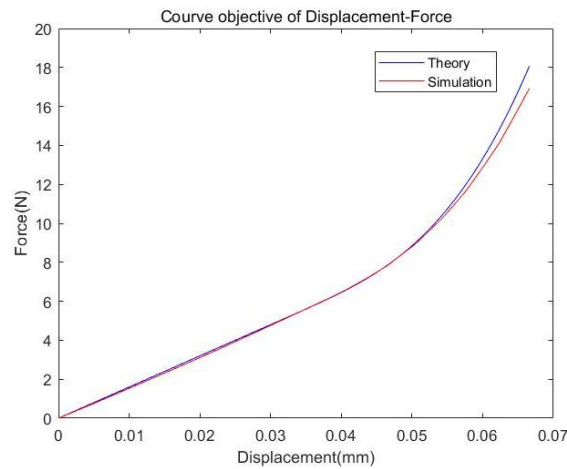

Figure 2: 3D model of variable pitch spring Figure 3: Comparison of theory and simulation

In the future, the following steps will be carried out:

- 1) Complete analysis of the whole system. Study the error between model predictions and experiments.
- 2) Study the dynamic behaviour of models in Abaqus, and investigate the possibility to simulate the phenomena of energy pumping.

After verifying the effectiveness of finite element models, we will develop an optimized NES system by experimentation with the aim towards industrial applications.

References

- [1] Starosvetsky, Y., & Gendelman, O. V. (2010). *Bifurcations of attractors in forced system with nonlinear energy sink: the effect of mass asymmetry*. *Nonlinear Dynamics*, 59(4), 711-731.
- [2] Bellet, R., Cochelin, B., Herzog, P., & Mattei, P. O. (2010). *Experimental study of targeted energy transfer from an acoustic system to a nonlinear membrane absorber*. *Journal of Sound and Vibration*, 329(14), 2768-2791.
- [3] Qiu, D., Paredes, M., & Seguy, S. (2019). *Variable pitch spring for nonlinear energy sink: Application to passive vibration control*. *Proceedings of the Institution of Mechanical Engineers, Part C: Journal of Mechanical Engineering Science*, 233(2), 611-622.