



**HAL**  
open science

## Distributed energy storage: Time-dependent tree flow design

A. Bejan, S. Ziaei, Sylvie Lorente

► **To cite this version:**

A. Bejan, S. Ziaei, Sylvie Lorente. Distributed energy storage: Time-dependent tree flow design. Journal of Applied Physics, 2016, 119 (18), pp.184901. 10.1063/1.4948663 . hal-01849697

**HAL Id: hal-01849697**

**<https://hal.insa-toulouse.fr/hal-01849697>**

Submitted on 13 Jun 2019

**HAL** is a multi-disciplinary open access archive for the deposit and dissemination of scientific research documents, whether they are published or not. The documents may come from teaching and research institutions in France or abroad, or from public or private research centers.

L'archive ouverte pluridisciplinaire **HAL**, est destinée au dépôt et à la diffusion de documents scientifiques de niveau recherche, publiés ou non, émanant des établissements d'enseignement et de recherche français ou étrangers, des laboratoires publics ou privés.

# Distributed energy storage: Time-dependent tree flow design

Cite as: J. Appl. Phys. **119**, 184901 (2016); <https://doi.org/10.1063/1.4948663>

Submitted: 23 March 2016 . Accepted: 22 April 2016 . Published Online: 09 May 2016

A. Bejan , S. Ziaei, and S. Lorente



View Online



Export Citation



CrossMark

## ARTICLES YOU MAY BE INTERESTED IN

[Morphing tree structures for latent thermal energy storage](#)

Journal of Applied Physics **117**, 224901 (2015); <https://doi.org/10.1063/1.4921442>

[The S curve of energy storage by melting](#)

Journal of Applied Physics **116**, 114902 (2014); <https://doi.org/10.1063/1.4894869>

[Hierarchy in air travel: Few large and many small](#)

Journal of Applied Physics **122**, 024904 (2017); <https://doi.org/10.1063/1.4993580>

## Lock-in Amplifiers up to 600 MHz

starting at

\$6,210



 Zurich  
Instruments

Watch the Video



## Distributed energy storage: Time-dependent tree flow design

A. Bejan,<sup>1</sup> S. Ziaei,<sup>1</sup> and S. Lorente<sup>2</sup>

<sup>1</sup>*Department of Mechanical Engineering and Materials Science, Duke University, Durham, North Carolina 27708-0300, USA*

<sup>2</sup>*Université de Toulouse, INSA, 135 Avenue de Rangueil, 31077 Toulouse, France*

(Received 23 March 2016; accepted 22 April 2016; published online 9 May 2016)

This article proposes “distributed energy storage” as a basic design problem of distributing energy storage material on an area. The energy flows by fluid flow from a concentrated source to points (users) distributed equidistantly on the area. The flow is time-dependent. Several scenarios are analyzed: sensible-heat storage, latent-heat storage, exergy storage vs energy storage, and the distribution of a finite supply of heat transfer surface between the source fluid and the distributed storage material. The chief conclusion is that the finite amount of storage material should be distributed proportionally with the distribution of the flow rate of heating agent arriving on the area. The total time needed by the source stream to “invade” the area is cumulative (the sum of the storage times required at each storage site) and depends on the energy distribution paths and the sequence in which the users are served by the source stream. Directions for future designs of distributed storage and retrieval are outlined in the concluding section. *Published by AIP Publishing.*

[<http://dx.doi.org/10.1063/1.4948663>]

### I. INTRODUCTION

The natural tendency of flow systems that are free to morph is to evolve into configurations that provide easier access over time. This phenomenon is visible throughout nature, from river basins to lungs, vascular tissues, city traffic, and the internet. The features of these flow designs are documented empirically in their respective fields (geophysics, biology, technology, etc.). This tendency unites the inanimate flow systems with the animate, social, and engineered, and in physics it is summarized as the constructal law.<sup>1,2</sup>

The visible manifestation of this universal tendency is the occurrence and evolution of flow organization everywhere (design and configuration). In flow systems that connect discrete points with *infinite* numbers of points (lines, areas, and volumes) the organization that emerges is commonly recognized as trees. The same tendency is also recognized as a hierarchical distribution of areas to channels: few large and many small, large interstices between large branches, and small interstices between small branches. These features of organization are being predicted in diverse fields by invoking the constructal law.<sup>2-5</sup>

The evolutionary phenomenon of configuring better flow architectures based on the constructal law is the subject of constructal design.<sup>6</sup> The work that has been devoted so far to flows between discrete points and areas and volumes dealt with *steady* flows. In every flow system of this kind, the emerging flow architecture is a tree that improves over time as the natural mechanisms of evolution play their part, for example, bed erosion in river flow, mutation in animal design, technology evolution in power grid design, new vehicles for city traffic, etc. The only time-dependent aspect of the emerging flow designs is evolution itself, the change from one configuration to the next, which is a better flowing configuration.

In this paper, we propose to extend the method of constructal design to the much wider and more general class of

point-area and point-volume flows that are time-dependent. All the tree-shaped examples studied so far, and mentioned earlier, are in reality not steady. The river basin swells and retreats, the vascular tissue grows and recedes, the flows of the economy accelerate and decelerate, the population grows and recedes, and the city infrastructure does the same. The time-dependent phenomenon can be described broadly as having an S-shaped history: initial slow growth is followed by fast growth, and then by slow growth again, tending to a plateau of steady flow.<sup>7,8</sup>

Time-dependent flows have one characteristic that is absent in steady flows. It is the ability to store temporarily a fraction of what flows, and to release that fraction to the flow architecture later. Storage and retrieval are possible because of the presence of physical features that accommodate these temporary changes. We see them as side lakes and marshes along rivers, which swell during the heavy rain. We see them in energy storage systems of many kinds in power generation and distribution systems.<sup>9-17</sup> These are the features that make the constructal architectures in this paper new and more challenging than in models of steady-flow applications.

### II. HOT STREAM FROM POINT TO AREA

Consider the flow of power from a central plant to the inhabitants on the area allocated to the plant. The power flows in two ways: (i) quasi periodically, in accord with the daily and seasonal cycles, and (ii) randomly, according to needs dictated by the weather (heat waves, polar air, hurricanes, etc.) (Fig. 1). We begin with the first phase of a time-varying flow: storage. The flow originates from the point, and it is stored temporarily on the area. The driver of the evolutionary design is the human need to reduce the losses during the point-area flow, and the losses that occur during the storage process itself.

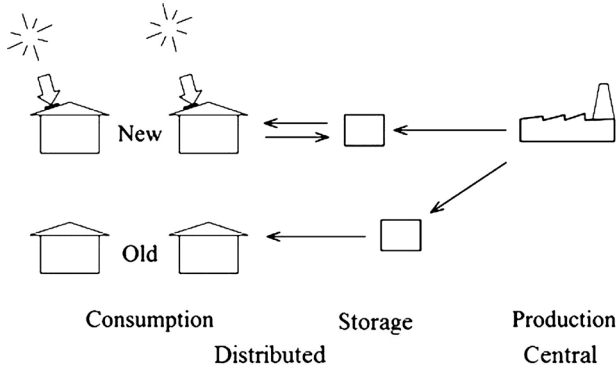

FIG. 1. Power generation and consumption are one point-area flow system. The area (the population) has a particular size that is allocated to one point (the power plant). On a multi-year time scale, changes (old  $\rightarrow$  new) occur in the technologies that facilitate the flow of power generation, distribution, and consumption.

We illustrate this design challenge by considering the time-dependent design, on the background provided by the steady flow (no storage) design of the distribution system. In the steady design, water is heated at a central location, and then distributed equally to users spread uniformly on an area. The losses that occur during this distributive flow are of two kinds: the pumping power needed to overcome fluid friction in all the ducts and heat leaks through the insulation wrapped around the ducts. The resulting flow architectures are tree-shaped, in two or three dimensions.<sup>18,19</sup>

In the time-dependent (storage) version of the design, the stream of hot water originates from one point and reaches many points (users) on the area, each point being represented by an amount of storage material (sensible heat or latent heat). The total amount of storage material spread on the area is specified, finite, and fixed. The challenge is to determine the location and size of each amount of storage material. It is to discover the configuration of the “distributed storage system.”

### III. STORAGE

A simple way to start is to decouple the design features that prevail in steady flow from the special features that are present when the storage process happens. The steady flow features are the tree-shaped architecture of ducts and the finite-size insulation distributed on it.<sup>18</sup> We assume that this flow architecture is known and in place.

An additional characteristic of tree-shaped flow architectures is their robustness. The global flow performance of the design does not change significantly if one duct is blocked.<sup>20</sup> The effect of the blockage is smaller and the robustness is greater when the tree design is more complex, that is, when the flow is distributed to a larger number of users on the area. This characteristic is essential at this stage, because we can use a relatively simple tree architecture (Fig. 2) with confidence that its global flow performance is comparable with (albeit below that of) tree architectures optimized in the presence of more degrees of freedom. For example, the branching angles in Fig. 2 are fixed at  $180^\circ$  (the bifurcations are T-shaped), although in a freely changing Y-shaped construct the optimal bifurcation angle is close to  $75^\circ$ .<sup>8,17</sup>

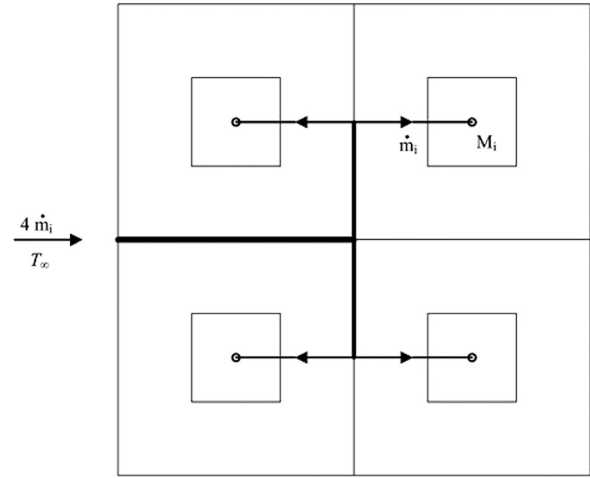

FIG. 2. The distribution of storage material ( $M_i$ ) on an area bathed by one stream configured as a point-area tree flow architecture.

Left to determine for the distributed storage system is the allocation of storage material ( $M_i$ ) at every point ( $i$ ) to which the tree flow structure brings a specified stream of hot fluid ( $\dot{m}_i$ ). The total mass of the storage material is  $M = \sum M_i$ , and it is fixed. The area allocated to every point is a unit square. How to allocate the storage mass at one point depends on the storage process: sensible heating versus latent heating (melting).

### IV. SENSIBLE HEATING

Assume that the heat losses along the distribution lines are negligible and the hot stream  $\dot{m}_i$  enters  $M_i$  at the source temperature  $T_\infty$ . In time, the temperature of the material ( $T$ ) rises from its initial level ( $T_0$ , ambient) to  $T_\infty$ . The most fundamental aspect in the design of any storage system is the purpose (the objective) of the design. Purpose accounts for what is being stored.

The source stream  $\dot{m}_i$  carries two finite and useful inventories with it. One is its enthalpy relative to the dead state,  $\dot{m}_i c_p (T_\infty - T_0)$ . The other is its flow exergy relative to the dead state,  $\dot{m}_i c_p [T_\infty - T_0 - T_0 \ln(T_\infty/T_0)]$ , where we neglected the loss of exergy due to frictional pressure drops along the flow distribution network. The enthalpy inventory is converted partially into an increase in the internal energy of the sensible-heat material. The exergy inventory is converted partially into exergy stored in  $M_i$ , which can be used later to produce useful power.

The case of *exergy storage* is illustrated in Fig. 3. Exergy is brought in by  $\dot{m}_i$  and, after being stored partially in  $M_i$ , the remaining exergy is destroyed by the same  $\dot{m}_i$  as it mixes with the ambient. The system destroys exergy in two places. The first is inside  $M_i$ , where the destruction is due to the transfer of heat across the finite temperature difference between the stream (with a temperature varying from  $T_\infty$  at the inlet to  $T_{out}$  at the outlet) and the storage material,  $T(t)$ . The second place is downstream of  $M_i$ , where the destruction is due to the heat transfer irreversibility associated with the rejection of heat [ $\dot{Q}_0 = \dot{m}_i c_p (T_{out} - T_0)$ ] from the exhaust

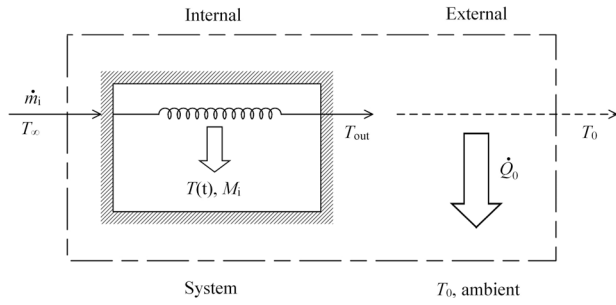

FIG. 3. The internal and external destruction of exergy during the sensible heat storage of exergy in the element  $M_i$  of Fig. 2.

(with a temperature varying from  $T_{out}$  to  $T_0$ ) to the ambient of temperature  $T_0$ .

The two locations of exergy destruction are labeled “internal” and “external” in Fig. 3. In the beginning, the internal destruction dominates, because in the beginning  $T \cong T_0$ ,  $T_{out} \cong T_0$ , and  $\dot{Q}_0$  is negligible. After a sufficiently long time,  $T$  and  $T_{out}$  approach  $T_\infty$ , and  $\dot{Q}_0$  approaches its maximum value. In this limit the external destruction of exergy dominates.

What matters is the sum of the two exergy destruction rates. The sum is minimum at the time when the internal and external contributions are comparable. As shown in Refs. 19 and 21, that special time ( $t$ ) is when the heat capacity of the hot fluid used is the same as the heat capacity of the storage material itself

$$\dot{m}_i c_p t \sim M_i c. \quad (1)$$

Here,  $c$  is the specific heat of the storage material, and  $t$  is the known time scale of the time-varying point-area flow system (e.g., Fig. 1).

The conclusion that follows from Eq. (1) is that the storage material ( $M_i$ ) must be distributed on the area of Fig. 2 in the same manner as the mini-streams ( $\dot{m}_i$ ). This means that the distribution of  $M_i$  must be uniform, because the dichotomous tree structure of Fig. 2 distributes the source stream uniformly, as one  $\dot{m}_i$  to each area element. If the tree flow distributes the  $\dot{m}_i$ 's nonuniformly, as in the tree construction based on quadrupling, as on the right side of Fig. 4, then the allocation of storage material to each area element ( $M_i$ ) should match the nonuniform distribution of exergy agent ( $\dot{m}_i$ ).

*Energy storage*, or the storage of “heating” in caloric terms, is a different objective. With respect to the system defined in Fig. 3, the objective is to raise the temperature of  $M_i$  from  $T_0$  to a final temperature,  $T_f$ . Heated to this higher temperature, the storage material can be used as heating agent during a subsequent heating process that occurs locally on the area allocated to the stream  $\dot{m}_i$ .

The analysis of the energy storage process consists of writing that the instantaneous heating rate provided by the stream matches the increase in the energy of  $M_i$

$$\dot{m}_i c_p (T_\infty - T_{out}) = M_i c \frac{dT}{dt} \quad (2)$$

with

$$T_\infty - T_{out} = \varepsilon_i (T_\infty - T), \quad (3)$$

$$\varepsilon_i = 1 - e^{-N_i}, \quad (4)$$

where  $\varepsilon_i$  is the effectiveness, and  $N_i = (UA)_i / (\dot{m}_i c_p)$  is the number of heat transfer units of the heat exchanger embedded in  $M_i$ . Eliminating  $T_{out}$  between Eqs. (2) and (3), and integrating the resulting equation from  $T = T_0$  at  $t = 0$  to  $T = T_f$  at  $t$ , we obtain

$$\frac{\dot{m}_i c_p \varepsilon_i}{M_i c} t = \ln \frac{T_\infty - T_0}{T_\infty - T_f}. \quad (5)$$

This result looks like Eq. (1), except for the factor  $\varepsilon_i$ , which depends on heat-transfer surface size  $(UA)_i$  and  $\dot{m}_i$ . The question is how to distribute the amount of storage material on the entire area when the total amount is fixed,

$$\sum_i M_i = \text{constant} \quad (6)$$

and the total heat exchanger inventory is to be minimized,  $\sum_i (UA)_i$ , or  $\sum_i N_i$  when  $\dot{m}_i = \text{constant}$ . According to the method of undetermined coefficients (e.g., Ref. 22, p. 844), this problem is equivalent to selecting the values  $M_i$  such that the aggregate sum  $S$  reaches an extremum

$$S = \sum_i N_i + \lambda \sum_i M_i, \quad (7)$$

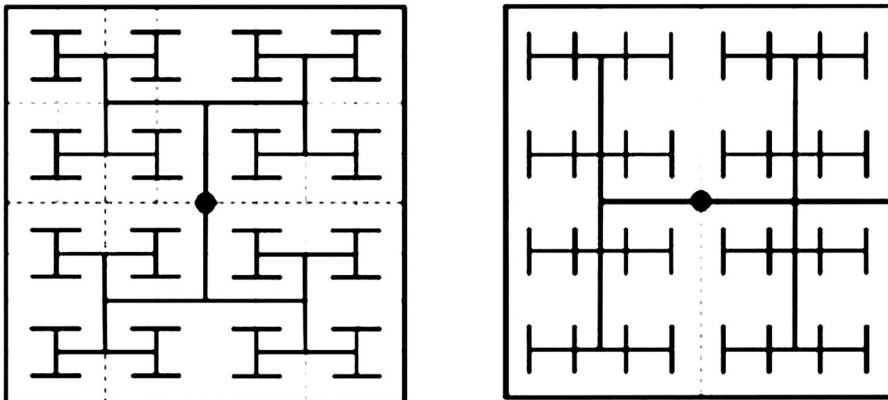

FIG. 4. Tree-shaped flow distribution networks based on doubling (left) and quadrupling (right) as the rule of construction.<sup>19</sup>



where  $\lambda$  is a Lagrange multiplier. According to Eq. (5), in which  $t$  is a constant (the known time interval of operation, for example, daily),  $N_i$  is proportional to  $-\ln(1 - M_i)$ , and Eq. (7) is replaced by

$$S = \sum_i -\ln(1 - M_i) + \lambda' \sum_i M_i, \quad (8)$$

where  $\lambda'$  is another constant factor. The extremum is located by solving the system  $\partial S / \partial M_i = 0$ , which yields the design solution

$$M_i = 1 + \frac{1}{\lambda'}, \quad \text{constant}. \quad (9)$$

In conclusion, when  $\dot{m}_i$  is distributed uniformly, the storage material  $M_i$  and the heat exchanger size  $[(UA)_i$  or  $N_i]$  should also be distributed uniformly.

## V. LATENT HEAT STORAGE

When  $M_i$  is a phase-change material, the key properties are the melting temperature  $T_m$  and the latent heat of melting  $h_{sf}$ . The analysis proceeds along the same lines as in Sec. IV. For example, if the objective of  $M_i$  is the store *exergy*, then the tradeoff between the internal and external exergy-destruction mechanisms (Fig. 3) leads to the conclusion that the material must be selected such that its melting point is<sup>22</sup>

$$T_m = (T_\infty T_0)^{1/2}. \quad (10)$$

Next comes the question of how large each  $M_i$  should be. For this we note that the heat transfer rate into the  $T$  material is  $q_i = \dot{m}_i c_P \varepsilon_i (T_\infty - T_m)$ , for which  $\varepsilon_i$  is given by Eq. (4). The energy transferred by heating the amount  $M_i$  during the time interval of operation  $t$  is  $\dot{m}_i t c_P \varepsilon_i (T_\infty - T_m)$ , where  $\varepsilon_i$  depends on the heat transfer area,  $N_i$  (cf. Eq. (4)). This energy transfer matches the latent heat of melting of the storage material,  $M_i h_{sf}$ . From this follows that  $M_i$  should be distributed on the landscape in proportion with the product  $\dot{m}_i \varepsilon_i$ , which depends on  $\dot{m}_i$  and  $N_i$ . Because the tree design distributes the  $\dot{m}_i$ 's uniformly (cf. Fig. 2), this means that the  $M_i$ 's should be distributed the same way as the  $N_i$ 's subject to fixed total amounts of both  $M$  and  $N$ . The analysis that follows is the same as in Eqs. (6)–(9) and the conclusion is the same: the phase-change material  $M_i$  and the heat exchanger size  $N_i$  should be distributed uniformly on the area.

## VI. INVASION TIME

Along with any heat storage process comes a characteristic time scale, the charging time. When the storage process is distributed over an area, the storage “invades” the area, and the charging times registered locally (at individual storage sites) compound themselves into an “invasion” time that characterizes the entire area that is used for storage.

To illustrate the physics basis for the invasion time, consider first the time needed to store energy (or exergy) in one of the units of phase-change material ( $M_i$ ) shown in Fig. 2. The material type is selected; therefore, its melting temperature  $T_m$  is fixed. The hot fluid of temperature  $T_\infty$  and

mass flow rate  $\dot{m}_i$  comes in contact with  $M_i$ , and heats it at the rate

$$\dot{Q}_m = \varepsilon_i \dot{m}_i c_P (T_\infty - T_m), \quad (11)$$

where the effectiveness is

$$\varepsilon_i = 1 - e^{-N_i} \quad (12)$$

and the number of heat transfer units is  $N_i = UA_i / (\dot{m}_i c_P)$ . Note that  $\dot{Q}_m$  is time dependent. Integrated over the charging time period  $t_i$ , the heat transfer matches the enthalpy rise experienced by  $M_i$ , namely,  $\dot{Q}_m t_i = M_i h_{sf}$ , from which follows the local invasion time

$$t_i = \frac{M_i h_{sf}}{\varepsilon_i \dot{m}_i c_P (T_\infty - T_m)}. \quad (13)$$

In view of the conclusion to Sec. V, the local dimensions  $(\dot{m}_i, N_i, M_i)$  are distributed uniformly over the area; therefore, if all the storage units  $M_i$  are accessed by their respective  $\dot{m}_i$ 's at the same time, then the entire area is invaded by storage during one  $t_i$  interval.

In practice, the scheme of flow distribution by doubling (from one stream  $4\dot{m}_i$  to many  $\dot{m}_i$ 's Fig. 2) is neither available nor easy to implement. More practical is the design where there is a single stream (a single supplier) of hot fluid  $\dot{m}_1$ , and this stream is used in order to melt in a certain sequence the storage units  $M_i$  on the available area. The hot stream  $\dot{m}_1$  visits the storage units in a particular sequence  $(M_1, M_2, \dots, M_n)$ ; each storage unit requires its own invasion time  $(t_1, t_2, \dots, t_n)$ ; and, as a consequence, the invasion time of storage on the area is the compounded time

$$t = t_1 + t_2 + \dots + t_n. \quad (14)$$

The storage invasion of the area is illustrated in Fig. 5. The single stream of heating agent  $\dot{m}_1$  heats the storage units in sequence, not simultaneously. The heating of one storage unit (say  $M_i$ ) is not influenced by the heating experienced earlier by the units in which energy (or exergy) was stored already  $(M_1, M_2, \dots, M_{i-1})$ .

The actual sequence in which the storage units are accessed can vary: the choices are more numerous when the storage sites are many. For example, in Fig. 5 the total length of the “string” design (a) is greater than the total length of the “radial” design (b). The total length is proportional to the rate of heat loss from the distribution lines during the invasion time required by storage on the area.

## VII. CONCLUDING REMARKS

In this article we identified the special design feature of distributing energy storage in time-dependent fashion on a territory, when the energy originates from a concentrated source. The flow is from point to area, and its distributing architecture results from tradeoffs between losses during storage and losses during the transport of energy from the source to the users on the area. The distribution scheme may be of several kinds (e.g., Figs. 2, 4, and 5).

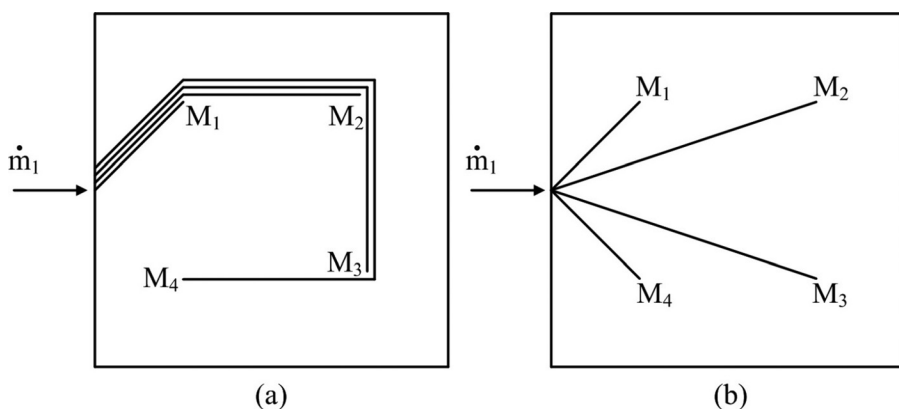

FIG. 5. Sequential storage at individual sites on the area, and the definition of the “invasion” time for storage on the area.

The special feature of this class of energy systems is that the finite storage material must be distributed in a certain way among the users on the area. To determine the architecture of distributed energy storage is the challenge.

We illustrated the first steps in this direction by considering sensible-heat storage, and by distributing a hot fluid stream to equidistant users on an area. We performed the analysis in two ways: for exergy storage and for the storage of heating. For both cases, we found that when the heating agent is distributed uniformly to the users, the storage material should also be allocated uniformly. This conclusion was reinforced by the corresponding analysis of the distribution of phase-change material for the storage of exergy. Furthermore, if the heating fluid is distributed nonuniformly on the area, then the storage material should be allocated nonuniformly, in proportion with the flow rates of heating fluid that arrive at each user point.

Important is the storage time, i.e., the duration of the “invasion” phenomenon during which energy (or exergy) flows from the source over the available area. The invasion time is cumulative (Eq. (14)) and depends on the distribution paths and the sequence in which the users are served by the source stream (e.g., Fig. 5).

The evolutionary designs outlined in this article serve as introduction to future designs that would complete the realization of practical storage facilities. One aspect that waits to be explored is the area-distribution of cooling (sensible heat and latent heat), which accounts for the retrieval of the stored energy. Another aspect is the distribution of heat transfer equipment (surface) of finite size during the retrieval phase, as we showed for sensible-heat storage in Section IV. The distribution of heat transfer surface on the area is a basic problem for both storage and retrieval. The problem can be addressed in two ways: for one heat transfer surface: between hot stream and storage material; and for two heat transfer surfaces: one between the hot stream and the storage material and the other between the storage material and the fluid stream that the user circulates through the storage material.

## ACKNOWLEDGMENTS

Professor Bejan’s research was supported by a grant from the National Science Foundation.

<sup>1</sup>A. Bejan, *The Physics of Life* (St. Martin’s Press, New York, 2016).

<sup>2</sup>A. Bejan and S. Lorente, “Constructal law of design and evolution: Physics, biology, technology, and society,” *J. Appl. Phys.* **113**, 151301 (2013).

<sup>3</sup>A. H. Reis, “Constructal theory: From engineering to physics, and how flow systems develop shape and structure,” *Appl. Mech. Rev.* **59**, 269–282 (2006).

<sup>4</sup>L. Chen, “Progress in study on constructal theory and its applications,” *Sci. China, Tech. Sci.* **55**, 802–820 (2012).

<sup>5</sup>A. Bachtá, J. Dhombres, and A. Kremer-Marietti, *Trois Études sur la Loi Constructale d’Adrian Bejan* (L’Harmattan, Paris, 2008).

<sup>6</sup>A. Bejan and S. Lorente, *Design with Constructal Theory* (Wiley, Hoboken, 2008).

<sup>7</sup>A. Bejan and S. Lorente, “The constructal law origin of the logistics S curve,” *J. Appl. Phys.* **110**, 024901 (2011).

<sup>8</sup>A. Bejan and S. Lorente, “The physics of spreading ideas,” *Int. J. Heat Mass Transfer* **55**, 802–807 (2012).

<sup>9</sup>*Thermal Energy Storage: Systems and Applications*, 2nd ed., edited by I. Dincer and M. A. Rosen (Wiley, Chichester, 2010).

<sup>10</sup>J. Banaszek, R. Domanaski, M. Rebow, and F. El-Sagier, “Experimental study of solid-liquid phase change in a spiral thermal energy storage unit,” *Appl. Therm. Eng.* **19**, 1253–1277 (1999).

<sup>11</sup>A. Trp, “An experimental and numerical investigation of heat transfer during technical grade paraffin melting and solidification in a shell-and-tube latent thermal energy storage unit,” *Sol. Energy* **79**, 648–660 (2005).

<sup>12</sup>L. A. Chidambaram, A. S. Ramana, G. Kamaraj, and R. Velraj, “Review of solar cooling methods and thermal storage options,” *Renewable Sustainable Energy Rev.* **15**, 3220–3228 (2011).

<sup>13</sup>W. Ogoh and D. Groulx, “Effects of the number and distribution of fins on the storage characteristics of a cylindrical latent heat energy storage system: A numerical study,” *Heat Mass Transfer* **48**, 1825–1835 (2012).

<sup>14</sup>M. Avci and M. Y. Yazici, “Experimental study of thermal energy storage characteristics of a paraffin in a horizontal tube-in-shell storage unit,” *Energy Convers. Manage.* **73**, 271–277 (2013).

<sup>15</sup>A. Sciacovelli, E. Guelpa, and V. Verda, “Second law optimization of a PCM based latent heat thermal energy storage system with tree shaped fins,” *Int. J. Thermodyn.* **17**, 127–136 (2014).

<sup>16</sup>K. Nithyanandam and R. Pitchumani, “Analysis and optimization of a latent thermal energy storage system with embedded heat pipes,” *Int. J. Heat Mass Transfer* **54**, 4596–4610 (2011).

<sup>17</sup>A. Sciacovelli, F. Gagliardi, and V. Verda, “Maximization of performance of a PCM latent heat storage system with innovative fins,” *Appl. Energy* **137**, 707–715 (2015).

<sup>18</sup>W. Wechsatoł, S. Lorente, and A. Bejan, “Tree-shaped insulated designs for the uniform distribution of hot water over an area,” *Int. J. Heat Mass Transfer* **44**, 3111–3123 (2001).

<sup>19</sup>L. A. O. Rocha, S. Lorente, and A. Bejan, “Distributed energy tapestry for heating the landscape,” *J. Appl. Phys.* **108**, 124904 (2010).

<sup>20</sup>W. Wechsatoł, S. Lorente, and A. Bejan, “Tree-shaped networks with loops,” *Int. J. Heat Mass Transfer* **48**, 573–583 (2005).

<sup>21</sup>A. Bejan, “Two thermodynamic optima in the design of sensible heat units for energy storage,” *J. Heat Transfer* **100**, 708–712 (1978).

<sup>22</sup>A. Bejan, *Advanced Engineering Thermodynamics*, 3rd ed. (Wiley, Hoboken, 2006).